

# **Available Transfer Capability Definitions and Determination**

**A Framework for Determining  
Available Transfer Capabilities of the  
Interconnected Transmission Networks for a  
Commercially Viable Electricity Market**



**N**orth American  
**E**lectric  
**R**eliability  
**C**ouncil

# Available Transfer Capability Definitions and Determination

---

*A framework for  
determining available transfer capabilities  
of the interconnected transmission networks  
for a commercially viable  
electricity market*

---



**North American Electric Reliability Council**

June 1996

# CONTENTS

---

<b>EXECUTIVE SUMMARY</b> .....	1
<b>INTRODUCTION</b> .....	4
Background .....	4
Terminology Convention .....	4
NERC Strategic Initiative .....	4
Purpose of This Report .....	5
<b>AVAILABLE TRANSFER CAPABILITY PRINCIPLES</b> .....	6
<b>TRANSMISSION TRANSFER CAPABILITY CONCEPTS</b> .....	7
Transfer Capability .....	7
Transfer Capability versus Transmission Capacity .....	7
Determination of Transfer Capability .....	7
Limits to Transfer Capability .....	8
Uses of Transmission Systems .....	9
<b>TTC DEFINITION AND DETERMINATION</b> .....	10
Definition of Total Transfer Capability .....	10
Determination of Total Transfer Capability .....	10
System Conditions .....	10
Critical Contingencies .....	11
System Limits .....	11
Parallel Path Flows .....	12
Non-Simultaneous and Simultaneous Transfers .....	12
<b>TRANSMISSION TRANSFER CAPABILITY MARGINS</b> .....	13
Technical Basis .....	13
Definition of Transmission Reliability Margin .....	13
Uncertainty in TTC and ATC Calculations .....	14
Need for Operating Flexibility .....	14
Definition of Capacity Benefit Margin .....	14
<b>ATC DEFINITION AND DETERMINATION</b> .....	15
Definition of Available Transfer Capability .....	15
Determination of Available Transfer Capability .....	15
Commercial Components of Available Transfer Capability .....	15
Curtailability .....	16
Recallability .....	16
Recallable and Non-recallable Relationships and Priorities .....	18
Scheduled and Reserved Transmission Service .....	18
Transmission Service Priorities .....	19
<b>Appendix A. NETWORK RESPONSE METHOD FOR ATC DETERMINATION</b> .....	22
<b>Appendix B. RATED SYSTEM PATH METHOD FOR ATC DETERMINATION</b> .....	29
<b>Appendix C. TRANSMISSION SERVICE RESERVATIONS AND SCHEDULING</b> .....	35
<b>TRANSMISSION TRANSFER CAPABILITY TASK FORCE</b> .....	40

# EXECUTIVE SUMMARY

---

This report, *Available Transfer Capability Definitions and Determination*, is in response to a NERC Strategic Initiative to “develop uniform definitions for determining Available (Transmission) Transfer Capability (ATC) and related terms that satisfy both [Federal Energy Regulatory Commission] FERC and electric industry needs, and which are to be implemented throughout the industry.” The NERC Board of Trustees at its May 13–14, 1996 meeting approved this report and endorsed its use by all segments of the electric industry.

The report establishes a framework for determining ATCs of the interconnected transmission networks for a commercially viable wholesale electricity market. The report also defines the ATC Principles under which ATC values are to be calculated. It is non-prescriptive in that it permits individual systems, power pools, subregions, and Regions to develop their own procedures for determining or coordinating ATCs based on a regional or wide-area approach in accordance with the Principles defined herein. The proposed ATC calculation framework is based on the physical and electrical characteristics and capabilities of the interconnected networks as applicable under NERC, Regional, subregional, power pool, and individual system reliability planning and operating policies, criteria, or guides.

This report provides an initial framework on ATC that will likely be expanded and modified as experience is gained in its use and as more is learned about how the competitive electric power market will function. The U.S. Federal Energy Regulatory Commission’s final rules, Orders No. 888 and No. 889 pertaining to promoting wholesale competition through open access non-discriminatory transmission services by public utilities and an open access same-time information system, respectively, were issued April 24, 1996. The framework for the determination of ATC as outlined in this report is in accord with the key provisions of these rulemakings.

## ATC PRINCIPLES

The following Available Transfer Capability (ATC) Principles govern the development of the definition and determination of ATC and related terms. All transmission provider and user entities are expected to abide by these Principles.

1. ATC calculations must produce commercially viable results. ATCs produced by the calculations must give a reasonable and dependable indication of transfer capabilities available to the electric power market.
2. ATC calculations must recognize time-variant power flow conditions on the entire interconnected transmission network. In addition, the effects of simultaneous transfers and parallel path flows throughout the network must be addressed from a reliability viewpoint.
3. ATC calculations must recognize the dependency of ATC on the points of electric power injection, the directions of transfers across the interconnected transmission network, and the points of power extraction. All entities must provide sufficient information necessary for the calculation of ATC.
4. Regional or wide-area coordination is necessary to develop and post information that reasonably reflects the ATCs of the interconnected transmission network.

# EXECUTIVE SUMMARY

---

5. ATC calculations must conform to NERC, Regional, subregional, power pool, and individual system reliability planning and operating policies, criteria, or guides.
6. The determination of ATC must accommodate reasonable uncertainties in system conditions and provide operating flexibility to ensure the secure operation of the interconnected network.

The calculation of transfer capability is generally based on computer simulations of the operation of the interconnected transmission network under a specific set of assumed operating conditions. These simulations are typically performed “off line,” well before the systems approach that operational state. Each simulation represents a single “snapshot” of the operation of the interconnected network based on the projections of many factors. As such, they are viewed as reasonable indicators of network performance and available transfer capability.

## ATC DEFINITIONS

**Available Transfer Capability (ATC)** is a measure of the transfer capability remaining in the physical transmission network for further commercial activity over and above already committed uses. Mathematically, ATC is defined as the Total Transfer Capability (TTC) less the Transmission Reliability Margin (TRM), less the sum of existing transmission commitments (which includes retail customer service) and the Capacity Benefit Margin (CBM).

**Total Transfer Capability (TTC)** is defined as the amount of electric power that can be transferred over the interconnected transmission network in a *reliable* manner while meeting *all* of a specific set of defined pre- and post-contingency system conditions.

**Transmission Reliability Margin (TRM)** is defined as that amount of transmission transfer capability necessary to ensure that the interconnected transmission network is secure under a reasonable range of uncertainties in system conditions.

**Capacity Benefit Margin (CBM)** is defined as that amount of transmission transfer capability reserved by load serving entities to ensure access to generation from interconnected systems to meet generation reliability requirements.

**Curtaibility** is defined as the right of a transmission provider to interrupt all or part of a transmission service due to constraints that reduce the capability of the transmission network to provide that transmission service. Transmission service is to be curtailed only in cases where system reliability is threatened or emergency conditions exist.

**Recallability** is defined as the right of a transmission provider to interrupt all or part of a transmission service for any reason, including economic, that is consistent with FERC policy and the transmission provider’s transmission service tariffs or contract provisions.

**Non-recallable ATC (NATC)** is defined as TTC less TRM, less non-recallable reserved transmission service (including CBM).

# EXECUTIVE SUMMARY

**Recallable ATC (RATC)** is defined as TTC less TRM, less recallable transmission service, less non-recallable transmission service (including CBM). RATC must be considered differently in the planning and operating horizons. In the planning horizon, the only data available are recallable and non-recallable transmission service reservations, whereas in the operating horizon transmission schedules are known.

## ATC AND RELATED TERMS

ATC and related terms are depicted graphically below. They form the basis of a transmission service reservation system that will be used to reserve and schedule transmission services in the new, competitive electricity market.

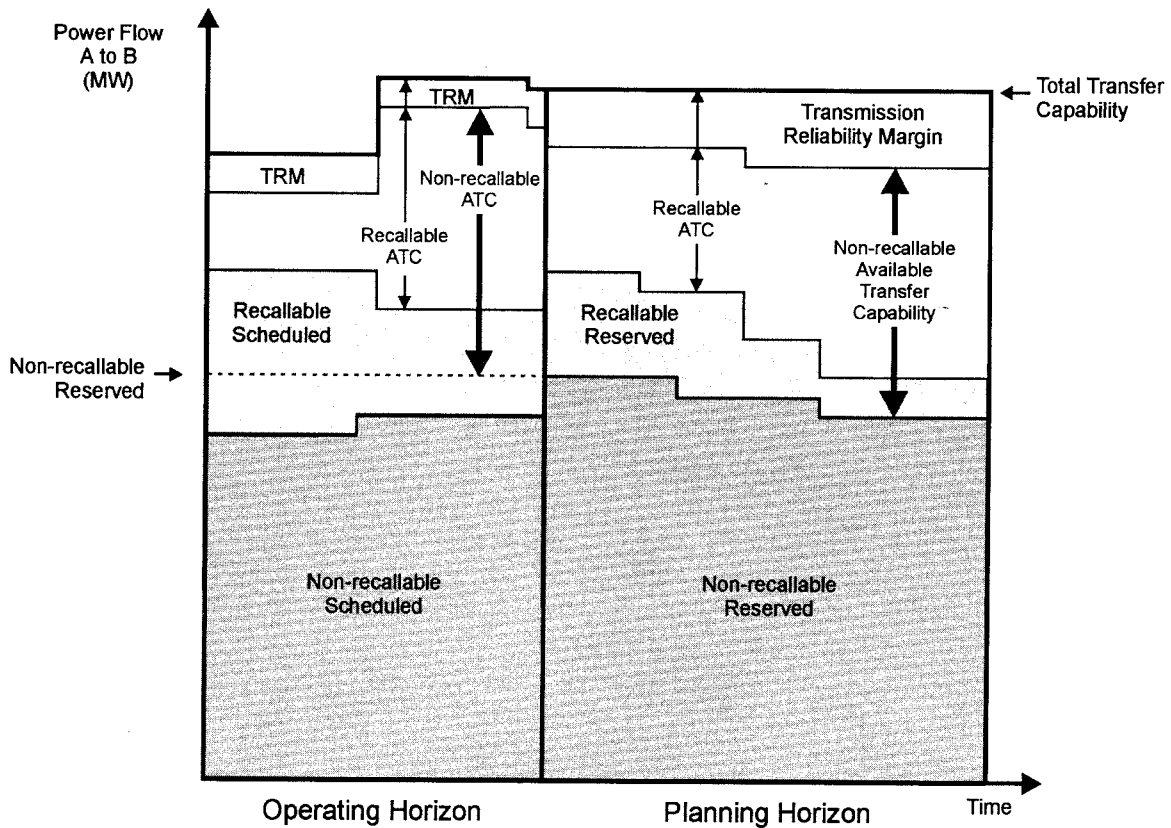

**TTC, ATC, and Related Terms in the Transmission Service Reservation System**

# INTRODUCTION

---

## BACKGROUND

Available Transmission Capacity as described in the U.S. Federal Energy Regulatory Commission's (FERC) March 29, 1995 Notice of Proposed Rulemaking (NOPR), Docket RM95-8-000, Section III-E4f, is a new term that has not been universally defined or used by the electric industry. The electric industry has historically used other standard terms, techniques, and methodologies to define and calculate meaningful measures of the transmission transfer capability of the interconnected transmission networks. These terms, which include First Contingency Total Transfer Capability (FCTTC) and First Contingency Incremental Transfer Capability (FCITC) as defined in NERC's May 1995 *Transmission Transfer Capability* reference document, are still applicable measures in an open transmission access environment. FERC's term Available Transmission Capacity and its definition and relationship to the industry's terminology need to be further clarified.

In its NOPR, FERC also requires that Available Transmission Capacity information be made available on a publicly accessible Real-time Information Network (RIN). Definitions of Available Transmission Capacity in the report of the industry's Electronic Information Network "What" Working Group, which was filed with FERC on October 16, 1995, are only considered to be assumptions to support the Working Group's effort in determining what information should be included on RINs. This report further refines those definitions.

It must be noted early in this report that electric systems in Canada and the northern portion of Baja California, Mexico, which are electrically interconnected with electric systems in the United States, are active members in NERC and the Regional Councils and are committed to promoting and maintaining interconnected electric system reliability. These non-U.S. systems are not, however, subject to FERC jurisdiction, and the commercial aspects of the definitions contained herein are not necessarily applicable to the operation of their internal transmission systems.

## TERMINOLOGY CONVENTION

FERC used the term Available Transmission Capacity in its NOPR to label the information that is to be made accessible to all transmission users as an indication of the available capability of the interconnected transmission networks to support additional transmission service. To avoid confusion with individual transmission line capacities or ratings, all references to "ATC" throughout this report will refer to Available (Transmission) Transfer Capability and its related terms as defined in this report.

## NERC STRATEGIC INITIATIVE

One of several *Strategic Initiatives for NERC*, approved by the NERC Board of Trustees on October 3, 1995, is to "develop uniform definitions for determining Available (Transmission) Transfer Capability and related terms that satisfy both FERC and electric industry needs, and which are to be implemented throughout the industry." The then existing NERC Transmission Transfer Capability Task Force, with expanded membership to include all segments of the electric industry, was assigned this responsibility for completion in May 1996.

# INTRODUCTION

---

## PURPOSE OF THIS REPORT

This report is the response to NERC's Strategic Initiative on ATC and defines ATC and related terms. From a commercial perspective, the key element in the development of uniform definitions for transmission transfer capability is the amount of transfer capability that is available at a given time for purchase or sale in the electric power market under various system conditions. Open access to the transmission systems places a new emphasis on the use of the interconnected networks. As such, future electric power transfers are anticipated to increase over a wide range of system conditions, making the reliable operation of the transmission networks more complex. To effectively maintain system reliability, those who calculate, report, post, and use this information must all have the same understanding of its meaning for commercial use. To accomplish this purpose, this report will answer the following questions:

- What is ATC?
- How does ATC relate to industry standard terminology?
- What physical factors need to be considered in determining ATC?
- What reliability issues must be considered in determining ATC?
- How is ATC calculated?
- How will ATC be commercially used?

The report establishes a framework for determining the ATCs of the interconnected transmission networks for a commercially viable electricity market. Although the report defines the ATC Principles under which ATCs are to be calculated, it is non-prescriptive in that it permits individual systems, power pools, sub-regions, and Regions to develop their own procedures for determining or coordinating ATCs based on a regional or wide-area approach in accordance with these Principles.

The report does not address transmission ownership and equity issues, nor does it address the allocation of transmission services or ATC values. The calculation of ATC is based strictly on the physical and electrical characteristics and capabilities of the interconnected networks as applicable under NERC, Regional, subregional, power pool, and individual system reliability planning and operating policies, criteria, or guides.

As the competitive electric power market develops, more will be learned on how these markets will function and how the definitions of ATC will be used. This report provides an initial framework on ATC, which will likely be expanded and modified as experience is gained in its use. The U.S. Federal Energy Regulatory Commission's final rules, Orders No. 888 and No. 889 pertaining to promoting wholesale competition through open access non-discriminatory transmission services by public utilities and an open access same-time information system, respectively, were issued April 24, 1996. The framework for the determination of ATC as outlined in this report is in accord with the key provisions of these rulemakings.



# AVAILABLE TRANSFER CAPABILITY PRINCIPLES

---

## ATC PRINCIPLES

Available Transfer Capability (ATC) is a measure of the transfer capability remaining in the physical transmission network for further commercial activity over and above already committed uses. As a measure bridging the technical characteristics of how interconnected transmission networks perform to the commercial requirements associated with transmission service requests, ATC must satisfy certain principles balancing both technical and commercial issues. ATC must accurately reflect the physical realities of the transmission network, while not being so complicated that it unduly constrains commerce. The following principles identify the requirements for the calculation and application of ATCs.

1. ***ATC calculations must produce commercially viable results. ATCs produced by the calculations must give a reasonable and dependable indication of transfer capabilities available to the electric power market.*** The frequency and detail of individual ATC calculations must be consistent with the level of commercial activity and congestion.
2. ***ATC calculations must recognize time-variant power flow conditions on the entire interconnected transmission network. In addition, the effects of simultaneous transfers and parallel path flows throughout the network must be addressed from a reliability viewpoint.*** Regardless of the desire for commercial simplification, the laws of physics govern how the transmission network will react to customer demand and generation supply. Electrical demand and supply cannot, in general, be treated independently of one another. All system conditions, uses, and limits must be considered to accurately assess the capabilities of the transmission network.
3. ***ATC calculations must recognize the dependency of ATC on the points of electric power injection, the directions of transfers across the interconnected transmission network, and the points of power extraction. All entities must provide sufficient information necessary for the calculation of ATC.*** Electric power flows resulting from each power transfer use the entire network and are not governed by the commercial terms of the transfer.
4. ***Regional or wide-area coordination is necessary to develop and post information that reasonably reflects the ATCs of the interconnected transmission network.*** ATC calculations must use a regional or wide-area approach to capture the interactions of electric power flows among individual, subregional, Regional, and multiregional systems.
5. ***ATC calculations must conform to NERC, Regional, subregional, power pool, and individual system reliability planning and operating policies, criteria, or guides.*** Appropriate system contingencies must be considered.
6. ***The determination of ATC must accommodate reasonable uncertainties in system conditions and provide operating flexibility to ensure the secure operation of the interconnected network.*** A Transmission Reliability Margin (TRM) may be necessary to apply this Principle. Additionally, transmission capability (defined as Capacity Benefit Margin or CBM) may need to be reserved to meet generation reliability requirements.

# TRANSMISSION TRANSFER CAPABILITY CONCEPTS

---

The key basic concepts of transmission transfer capability are described below. Numerous other terms related to transfer capability are explored in detail in NERC's May 1995 *Transmission Transfer Capability* reference document. The concepts and terms in that document are still applicable in an open transmission environment.

## TRANSFER CAPABILITY

Transfer capability is the measure of the ability of interconnected electric systems to *reliably* move or transfer power from one area to another over all transmission lines (or paths) between those areas under specified system conditions. The units of transfer capability are in terms of electric power, generally expressed in megawatts (MW). In this context, "area" may be an individual electric system, power pool, control area, subregion, or NERC Region, or a portion of any of these. Transfer capability is also directional in nature. That is, the transfer capability from Area A to Area B is *not* generally equal to the transfer capability from Area B to Area A.

## TRANSFER CAPABILITY VERSUS TRANSMISSION CAPACITY

Electric systems throughout NERC have agreed to use common terminology to calculate and report transmission transfer limits to maintain the reliability of the interconnected transmission networks. These transfer values are called "capabilities" (differentiating them from "capacities") because they are highly dependent on the generation, customer demand, and transmission system conditions assumed during the time period analyzed. The electric industry generally uses the term "capacity" as a specific limit or rating of power system equipment. In transmission, capacity usually refers to the thermal limit or rating of a particular transmission element or component. The ability of a single transmission line to transfer electric power, when operated as part of the interconnected network, is a function of the physical relationship of that line to the other elements of the transmission network.

Individual transmission line capacities or ratings *cannot* be added to determine the transfer capability of a transmission path or interface (transmission circuits between two or more areas within an electric system or between two or more systems). Such aggregated capacity values may be vastly different from the transmission transfer capability of the network. Often, the aggregated capacity of the individual circuits of a specific transmission interface between two areas of the network is greater than the actual transfer capability of that interface. In summary, the aggregated transmission line capacities of a path or interface do not represent the transfer capabilities between two areas.

## DETERMINATION OF TRANSFER CAPABILITY

The calculation of transfer capability is generally based on computer simulations of the operation of the interconnected transmission network under a specific set of assumed operating conditions. These simulations are typically performed "off line," well before the systems approach that operational state. Each simulation represents a single "snapshot" of the operation of the interconnected network based on the projections of many factors. As such, they are viewed as reasonable indicators of network performance and available transfer capability. Among the factors considered in these simulations are:

# TRANSMISSION TRANSFER CAPABILITY CONCEPTS

---

- **Projected Customer Demands** — Base case demand levels should be appropriate to the system conditions and customer demand levels under study and may be representative of peak, off-peak or shoulder, or light demand conditions.
- **Generation Dispatch** — Utility and nonutility generators should be realistically dispatched for the system conditions being simulated.
- **System Configuration** — The base case configuration of the interconnected systems should be representative of the conditions being simulated, including any generation and transmission outages that are expected. The activation of any operating procedures normally expected to be in effect should also be included in the simulations.
- **Base Scheduled Transfers** — The scheduled electric power transfers that should be modeled are those that are generally considered to be representative of the base system conditions being analyzed and which are agreed upon by the parties involved.
- **System Contingencies** — A significant number of generation and transmission system contingencies should be screened, consistent with individual electric system, power pool, subregional, and Regional planning criteria or guides, to ensure that the facility outage most restrictive to the transfer being studied is identified and analyzed. The contingencies evaluated may in some instances include multiple contingencies where deemed to be appropriate.

The conditions on the interconnected network continuously vary in real time. Therefore, the transfer capability of the network will also vary from one instant to the next. For this reason, transfer capability calculations may need to be updated periodically for application in the operation of the network. In addition, depending on actual network conditions, transfer capabilities can often be higher or lower than those determined in the off-line studies. The farther into the future that simulations are projected, the greater is the uncertainty in assumed conditions. However, transfer capabilities determined from simulation studies are generally viewed as reasonable indicators of actual network capability.

## LIMITS TO TRANSFER CAPABILITY

The ability of interconnected transmission networks to *reliably* transfer electric power may be limited by the physical and electrical characteristics of the systems including any one or more of the following:

- **Thermal Limits** — Thermal limits establish the maximum amount of electrical current that a transmission line or electrical facility can conduct over a specified time period before it sustains permanent damage by overheating or before it violates public safety requirements.
- **Voltage Limits** — System voltages and changes in voltages must be maintained within the range of acceptable minimum and maximum limits. For example, minimum voltage limits can establish the maximum amount of electric power that can be transferred without causing damage to the electric system or customer facilities. A widespread collapse of system voltage can result in a blackout of portions or all of the interconnected network.

# TRANSMISSION TRANSFER CAPABILITY CONCEPTS

---

- **Stability Limits** — The transmission network must be capable of surviving disturbances through the transient and dynamic time periods (from milliseconds to several minutes, respectively) following the disturbance. All generators connected to ac interconnected transmission systems operate in synchronism with each other at the same frequency (nominally 60 Hertz). Immediately following a system disturbance, generators begin to oscillate relative to each other, causing fluctuations in system frequency, line loadings, and system voltages. For the system to be stable, the oscillations must diminish as the electric systems attain a new, stable operating point. If a new, stable operating point is not quickly established, the generators will likely lose synchronism with one another, and all or a portion of the interconnected electric systems may become unstable. The results of generator instability may damage equipment and cause uncontrolled, widespread interruption of electric supply to customers.

The limiting condition on some portions of the transmission network can shift among thermal, voltage, and stability limits as the network operating conditions change over time. Such variations further complicate the determination of transfer capability limits.

## USES OF TRANSMISSION SYSTEMS

The interconnected transmission networks tie together major electric system facilities, generation resources, and customer demand centers. They are planned, designed, and constructed to operate reliably within thermal, voltage, and stability limits for the following purposes:

- **To Deliver Electric Power to Customers** — Transmission networks must provide for the reliable transfer of the electric power output from generation resources to customers under a wide variety of operating conditions.
- **To Provide Flexibility for Changing System Conditions** — Transmission capability must be available on the interconnected network to provide flexibility to reliably handle the shift in transmission facility loadings caused by maintenance and forced outages of generation and transmission equipment, and a wide range of variable system conditions, such as higher than expected customer demands, or construction delays of new facilities.
- **To Reduce the Need for Installed Generating Capacity** — Transmission interconnections between neighboring systems provide for the sharing of installed generating capacity, taking advantage of the diversity in customer demands and generation availability over a wide area, thereby reducing the amount of installed generating capacity necessary to meet generation reliability requirements in each of the interconnecting systems.
- **To Allow Economic Exchange of Electric Power Among Systems** — Transmission interconnections between systems, coupled with internal system transmission facilities, allow for the economic exchange of electric power among neighboring systems. Such economy transfers help reduce the overall cost of electricity to customers.

# TTC DEFINITION AND DETERMINATION

---

## DEFINITION OF TOTAL TRANSFER CAPABILITY

The Total Transfer Capability (TTC) between any two areas or across particular paths or interfaces is direction specific and consistent with the First Contingency Total Transfer Capability (FCTTC) as defined in NERC's May 1995 *Transmission Transfer Capability* reference document.

TTC is the amount of electric power that can be transferred over the interconnected transmission network in a *reliable* manner based on *all* of the following conditions:

1. For the existing or planned system configuration, and with normal (pre-contingency) operating procedures in effect, all facility loadings are within normal ratings and all voltages are within normal limits.
2. The electric systems are capable of absorbing the dynamic power swings, and remaining stable, following a disturbance that results in the loss of any single electric system element, such as a transmission line, transformer, or generating unit.
3. After the dynamic power swings subside following a disturbance that results in the loss of any single electric system element as described in 2 above, and after the operation of any automatic operating systems, but before any post-contingency operator-initiated system adjustments are implemented, all transmission facility loadings are within emergency ratings and all voltages are within emergency limits.
4. With reference to condition 1 above, in the case where pre-contingency facility loadings reach normal thermal ratings at a transfer level below that at which any first contingency transfer limits are reached, the transfer capability is defined as that transfer level at which such normal ratings are reached.
5. In some cases, individual system, power pool, subregional, or Regional planning criteria or guides may require consideration of specified multiple contingencies, such as the outage of transmission circuits using common towers or rights-of-way, in the determination of transfer capability limits. If the resulting transfer limits for these multiple contingencies are more restrictive than the single contingency considerations described above, the more restrictive reliability criteria or guides must be observed.

## DETERMINATION OF TOTAL TRANSFER CAPABILITY

The concepts for determining transfer capability described in NERC's *Transmission Transfer Capability* reference document are still valid and do not change with the advent of open transmission access or the need to determine ATCs. The major points contained therein are briefly outlined below.

### System Conditions

Base system conditions are identified and modeled for the period being analyzed, including projected customer demands, generation dispatch, system configuration, and base scheduled transfers. As system conditions change, the base system conditions under which TTC is calculated may also need to be modified.

# TTC DEFINITION AND DETERMINATION

## Critical Contingencies

During transfer capability studies, many generation and transmission system contingencies throughout the network are evaluated to determine which facility outages are most restrictive to the transfer being analyzed. The types of contingencies evaluated are consistent with individual system, power pool, subregional, and Regional planning criteria or guides. The evaluation process should include a variety of system operating conditions because as those conditions vary, the most critical system contingencies and their resulting limiting system elements could also vary.

## System Limits

As discussed earlier, the transfer capability of the transmission network may be limited by the physical and electrical characteristics of the systems including thermal, voltage, and stability considerations. Once the critical contingencies are identified, their impact on the network must be evaluated to determine the most restrictive of those limitations. Therefore, the TTC becomes:

$$\text{TTC} = \text{Minimum of } \{ \text{Thermal Limit, Voltage Limit, Stability Limit} \}$$

As system operating conditions vary, the most restrictive limit on TTC may move from one facility or system limit to another as illustrated in Figure 1.

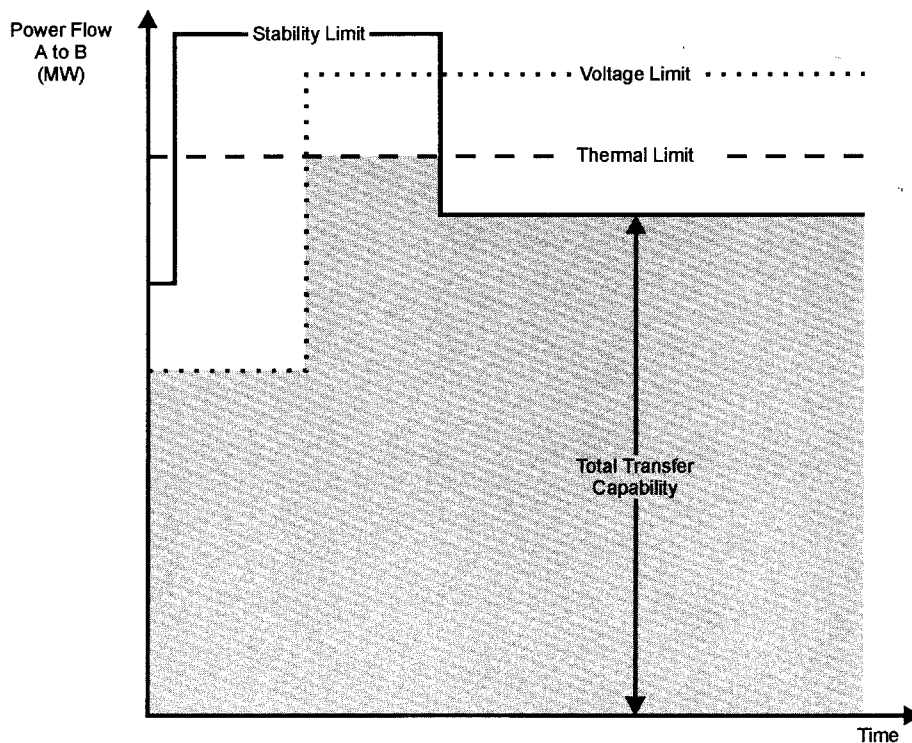

Figure 1: Limits to Total Transfer Capability

# TTC DEFINITION AND DETERMINATION

---

## **Parallel Path Flows**

When electric power is transferred across the network, parallel path flows occur. This complex electric transmission network phenomenon can affect all systems of an interconnected network, especially those systems electrically near the transacting systems. As a result, transfer capability determinations must be sufficient in scope to ensure that limits throughout the interconnected network are addressed. In some cases, the parallel path flows may result in transmission limitations in systems other than the transacting systems, which can limit the transfer capability between the two contracting areas.

## **Non-Simultaneous and Simultaneous Transfers**

Transfer capability can be determined by simulating transfers from one area to another independently and non-concurrently with other area transfers. These capabilities are referred to as “non-simultaneous” transfers. Another type of transfer capability reflects simultaneous or multiple transfers concurrently. These capabilities are developed in a manner similar to that used for non-simultaneous capability, except that the interdependency of transfers among the other areas is taken into account. These interdependent capabilities are referred to as “simultaneous” transfers. No simple relationship exists between non-simultaneous and simultaneous transfer capabilities. The simultaneous transfer capability may be lower than the sum of the individual non-simultaneous transfer capabilities.

# TRANSMISSION TRANSFER CAPABILITY MARGINS

---

Two types of transmission transfer capability margins include:

- Transmission Reliability Margin (TRM) — to ensure the secure operation of the interconnected transmission network to accommodate uncertainties in system conditions.
- Capacity Benefit Margin (CBM) — to ensure access to generation from interconnected systems to meet generation reliability requirements.

Individual systems, power pools, subregions, and Regions should identify their TRM and CBM procedures used to establish such transmission transfer capability margins as necessary. TRM and CBM should be developed and applied as separate and independent components of transfer capability margin. The specific methodologies for determining and identifying necessary margins may vary among Regions, subregions, power pools, individual systems, and load serving entities. However, these methodologies must be well documented and consistently applied.

## TECHNICAL BASIS

Electric systems historically have recognized the need for and benefits of transfer capability margins in the planning and operation of the interconnected transmission networks. In addition to meeting obligations for service to native load customers and deliveries for third-party transmission users, some reserve transmission transfer capability is required to ensure that the interconnected network is secure under a wide range of uncertain operational parameters. Also, systems have relied upon transmission import capability, through interconnections with neighboring systems, to reduce their installed generating capacity necessary to meet generation reliability requirements and provide reliable service to native load. With the introduction of mandatory, non-discriminatory access, and the resulting need to identify and provide current and projected ATCs to the competitive electric power market, a need now exists to formally address these two types of transmission transfer capability margins.

This report provides a framework to support the development of transfer capability margin procedures. TRM and CBM are concepts that may need to be further developed for general applicability while allowing for tailoring to specific Regional, subregional, power pool, and individual system conditions. As these margin concepts are developed and applied, NERC will review their implementation and consider the need for further guidance.

## DEFINITION OF TRANSMISSION RELIABILITY MARGIN

Transmission Reliability Margin (TRM) is defined as that amount of transmission transfer capability necessary to ensure that the interconnected transmission network is secure under a reasonable range of uncertainties in system conditions.

TRM provides a reserve of transfer capability that ensures the reliability of the interconnected transmission network. All transmission system users benefit from the assurance that transmission services will be reliable under a broad range of potential system conditions. TRM accounts for the inherent uncertainty in system conditions and their associated effects on TTC and ATC calculations, and the need for operating flexibility to ensure reliable system operation as system conditions change.



# TRANSMISSION TRANSFER CAPABILITY MARGINS

---

## **Uncertainty in TTC and ATC Calculations**

TTC and ATC determinations depend upon a myriad of assumptions and projections of system conditions, which may include such items as transmission system topology, projected customer demand and its distribution, generation dispatch, location of future generators, future weather conditions, available transmission facilities, and existing and future electric power transactions. Such parameters are assembled to produce a scenario to be used to project transfer capabilities under a reasonable range of transmission contingencies as specified in Regional, subregional, power pool, and individual system reliability operating and planning policies, criteria, or guides. Therefore, calculations of future TTCs and ATCs must consider the inherent uncertainties in projecting such system parameters over longer time periods. Generally, the uncertainties of TTC and ATC projections increase for longer term projections due to greater difficulty in being able to predict the various system assumptions and parameters over longer time periods. For instance, locations of future customer demands and generation sources are often quite uncertain, and these parameters have a potentially large impact on transfer capabilities. Similarly, future electric power transactions are inherently uncertain and can have significant impacts on transmission loadings. Therefore, the amount of TRM required is time dependent generally with a larger amount necessary for longer time projections than for near-term conditions. TRM must also have wide-area coordination.

## **Need for Operating Flexibility**

TTC and ATC calculations must recognize that actual system conditions may change considerably in short periods of time due to changing operating conditions, and cannot be definitively projected without the provision of a transfer capability margin. These operational conditions include changes in dispatch of generating units, simultaneous transfers scheduled by other systems that impact the particular area being studied, parallel path flows, maintenance outages, and the dynamic response of the interconnected systems to contingencies (including the sudden loss of generating units).

## **DEFINITION OF CAPACITY BENEFIT MARGIN**

Capacity Benefit Margin (CBM) is defined as that amount of transmission transfer capability reserved by load serving entities to ensure access to generation from interconnected systems to meet generation reliability requirements. Reservation of CBM by a load serving entity allows that entity to reduce its installed generating capacity below that which may otherwise have been necessary without interconnections to meet its generation reliability requirements.

The CBM is a more locally applied margin than TRM, which is more of a network margin. As such, to the extent a load serving entity maintains policies and procedures to reserve transfer capability for generation reliability purposes, the CBM should be included in the reserved or committed system uses in the calculation of ATC. These CBMs should continue to be a consideration in transmission system development. It is anticipated that individual load serving entities and regional planning groups will continue to address CBMs and that the NERC and Regional reviews of generation adequacy will continue to consider this capability. It is also anticipated that load serving entities will develop additional procedures for reserving transfer capability for generation capacity purposes and include these procedures in Regional planning reviews and regulatory filings as appropriate.

# ATC DEFINITION AND DETERMINATION

---

## DEFINITION OF AVAILABLE TRANSFER CAPABILITY

Available Transfer Capability (ATC) is a measure of the transfer capability remaining in the physical transmission network for further commercial activity over and above already committed uses. Mathematically, ATC is defined as the Total Transfer Capability (TTC) less the Transmission Reliability Margin (TRM), less the sum of existing transmission commitments (which includes retail customer service) and the Capacity Benefit Margin (CBM). ATC can be expressed as:

$$\text{ATC} = \text{TTC} - \text{TRM} - \text{Existing Transmission Commitments (including CBM)}$$

The ATC between two areas provides an indication of the amount of additional electric power that can be transferred from one area to another for a specific time frame for a specific set of conditions. ATC can be a very dynamic quantity because it is a function of variable and interdependent parameters. These parameters are highly dependent upon the conditions of the network. Consequently, ATC calculations may need to be periodically updated. Because of the influence of conditions throughout the network, the accuracy of the ATC calculation is highly dependent on the completeness and accuracy of available network data.

## DETERMINATION OF AVAILABLE TRANSFER CAPABILITY

The determination of ATCs and the relationship of electric power transactions and associated power flows on the transmission network are described in Appendixes A and B. The ATC calculation methodologies described in Appendixes A and B are not intended to prescribe a specific calculation procedure nor do they describe the only methods of calculating ATCs. Each Region, subregion, power pool, and individual system will have to consider the ATC Principles in this report and determine the best procedure for calculating ATCs based upon their respective circumstances.

Appendix A describes an ATC calculation approach that may be termed a “network response” method. This method is intended to be illustrative of a procedure that is applicable in highly dense, meshed transmission networks where customer demand, generation sources, and the transmission systems are tightly interconnected.

Appendix B describes another ATC calculation approach that may be referred to as a “rated system path” method. This method is intended to be illustrative of a procedure that is applicable in so-called sparse transmission networks where the critical transmission paths between areas of the network have been identified and rated as to their achievable transfer loading capabilities for a range of system conditions.

## COMMERCIAL COMPONENTS OF AVAILABLE TRANSFER CAPABILITY

To more fully define ATC, specific commercial aspects of transmission service must be considered. Because the terms “firm” and “non-firm” are used somewhat loosely within the electric industry, confusion often exists when these terms are used to characterize the basic nature of transmission services. To create reasonably consistent expectations regarding the transmission services that are being offered, the concepts of curtailability and recallability are introduced.

# ATC DEFINITION AND DETERMINATION

## Curtaibility

Curtaibility is defined as the right of a transmission provider to interrupt all or part of a transmission service due to constraints that reduce the capability of the transmission network to provide that transmission service. Transmission service is to be curtailed only in cases where system reliability is threatened or emergency conditions exist. Curtailment procedures, terms, and conditions will be identified in the transmission service tariffs. When such constraints no longer restrict the transfer capability of the transmission network, the transmission service may be resumed. Curtailment does not apply to situations in which transmission service is discontinued for economic reasons.

## Recallability

Recallability is defined as the right of a transmission provider to interrupt all or part of a transmission service for any reason, including economic, that is consistent with FERC policy and the transmission provider's transmission service tariffs or contract provisions.

Based on the recallability concept, two commercial applications of ATC are defined below and depicted graphically in Figure 2. They are as follows:

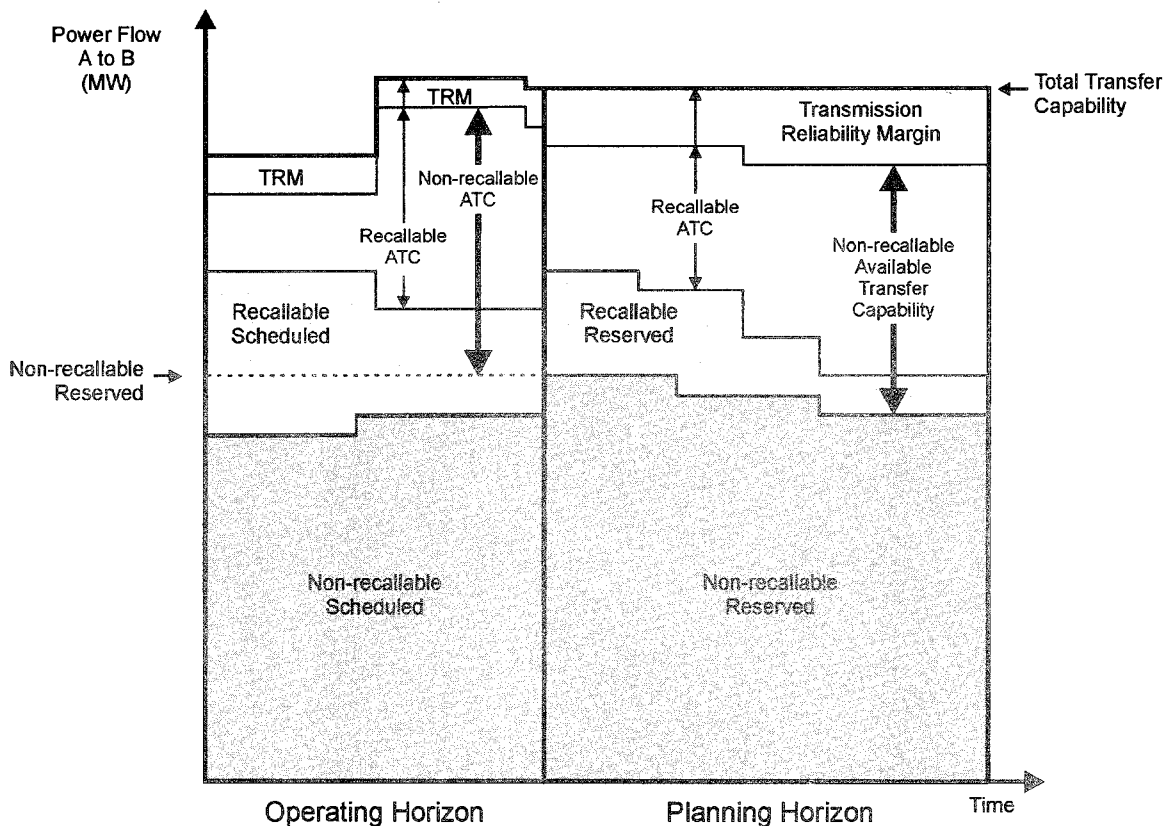

Figure 2: TTC, ATC, and Related Terms in the Transmission Service Reservation System

# ATC DEFINITION AND DETERMINATION

---

- **Non-recallable Available Transfer Capability** — Non-recallable ATC (NATC) is defined as TTC less TRM, less non-recallable reserved transmission service (including CBM). NATC has the highest priority use of the transmission network. The maximum amount of non-recallable service that can be reserved is determined based on what the network can reliably handle under normal operating conditions and during appropriate contingencies as defined in NERC, Regional, subregional, power pool, and individual system reliability operating and planning policies, criteria, or guides. Any lower priority service can be displaced by non-recallable service that is either new non-recallable service or non-recallable service that had been reserved but not scheduled.

Mathematically, NATC can be expressed as:

$$\text{NATC} = \text{TTC} - \text{TRM} - \text{Non-recallable Reserved Transmission Service (including CBM)}$$

- **Recallable Available Transfer Capability** — Recallable ATC (RATC) is defined as TTC less TRM, less recallable transmission service, less non-recallable transmission service (including CBM). Portions of the TRM may be made available by the transmission provider for recallable use, depending on the time frame under consideration for granting additional transmission service. To the extent load serving entities reserve transmission transfer capability for CBM, portions of CBM may be made available for recallable use, depending on the time frame under consideration for granting additional transmission service.

RATC has the lowest priority use on the transmission network and is recallable subject to the notice provisions of the transmission service tariffs. Recallable reserved service may be recalled in favor of subsequent requests for non-recallable transmission service. However, recallable reserved service has precedence over subsequent requests for recallable transmission service, unless the tariff or contract provisions specify otherwise. Because RATC is recallable on short notice, it can use the transfer capability reserved for higher priority service that has been reserved but not scheduled.

RATC must be considered differently in the planning and operating horizons. In the planning horizon, the only data available are recallable and non-recallable transmission service reservations, whereas in the operating horizon transmission schedules are known.

Mathematically, RATC can be expressed as:

a) Planning Horizon

$$\begin{aligned} \text{RATC} &= \text{TTC} \\ &\quad - a(\text{TRM}) \\ &\quad - \text{Recallable Reserved Transmission Service} \\ &\quad - \text{Non-recallable Reserved Transmission Service (including CBM)} \end{aligned}$$

where  $0 \leq a \leq 1$ , value determined by individual transmission providers based on network reliability concerns.

# ATC DEFINITION AND DETERMINATION

---

## b) Operating Horizon

$$\text{RATC} = \text{TTC}$$

- $b(\text{TRM})$
- Recallable Scheduled Transmission Service
- Non-recallable Scheduled Transmission Service (including CBM)

where  $0 \leq b \leq 1$ , value determined by individual transmission providers based on network reliability concerns.

NATC and RATC are depicted graphically in Figure 2. TTC, ATC, and related terms in the transmission service reservation system are also shown in Figure 2. In general, the transition between the planning and operating horizons will be a function of available information about the system, the status of reserved and scheduled transmission services, and time considerations.

## RECALLABLE AND NON-RECALLABLE RELATIONSHIPS AND PRIORITIES

The relationships and priorities of recallable and non-recallable concepts as they apply to both scheduled and reserved transmission services are described below. In addition, the interaction between recallable and non-recallable transmission services and the effects on ATC values are discussed and illustrated.

### Scheduled and Reserved Transmission Service

Reserved transmission service constitutes a reserved portion of the transmission network transfer capability, but the actual electric power transfer is not yet scheduled between areas. Scheduled transmission service indicates that an electric power transfer will be occurring on the transmission network for the time period for which the transmission service was reserved. Both terms can apply to either recallable or non-recallable transmission service, giving the following four transmission service terms:

- Non-recallable Reserved (NRES)
- Non-recallable Scheduled (NSCH)
- Recallable Reserved (RRES)
- Recallable Scheduled (RSCH)

The aggregate of the NSCH and RSCH must never exceed the TTC in the operational horizon. However, in the planning horizon, individual transmission providers may allow the aggregate of the NRES and RRES to exceed the TTC less TRM, to more fully utilize transmission assets, provided that NRES by itself never exceeds TTC less TRM. Such over-subscription of recallable reservations must be disclosed to the purchasers of RRES. These ATC relationships are shown in Figure 3.

# ATC DEFINITION AND DETERMINATION

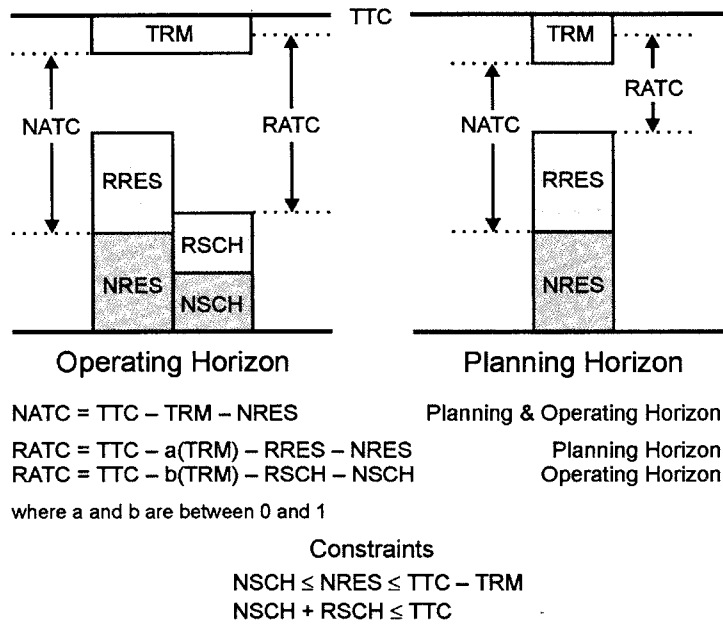

Transfer Capabilities	Transmission Services
TTC — Total Transfer Capability	NRES — Non-recallable Reserved
ATC — Available Transfer Capability	NSCH — Non-recallable Scheduled
RATC — Recallable ATC	RRES — Recallable Reserved
NATC — Non-recallable ATC	RSCH — Recallable Scheduled

Figure 3: ATC Relationships

## Transmission Service Priorities

Non-recallable and recallable transmission service must adhere to a standard set of priorities universally applied throughout the electric power market to avoid confusion. These priorities are described below.

- Non-recallable service has priority over recallable service. Recallable transfers, reserved or scheduled, may be recalled for non-recallable requests. Recallability will generally be applied as needed only in areas of network constraint and not unilaterally over the entire network.
- All requests for transmission service will be evaluated in priority as established by applicable transmission service tariffs.
- Reserved transfer capability may be used by recallable scheduled transfers, provided that those scheduled transfers can be recalled if the reserved transfer requester wants to make use of the reserved transfer capability.

# ATC DEFINITION AND DETERMINATION

Several of the possible relationships of NATCs and RATCs to the different types of transfers that have been scheduled or reserved during a given time period are shown in Figure 4 and described below. These concepts apply to any time during the forecast period. Therefore, no time aspect is identified.

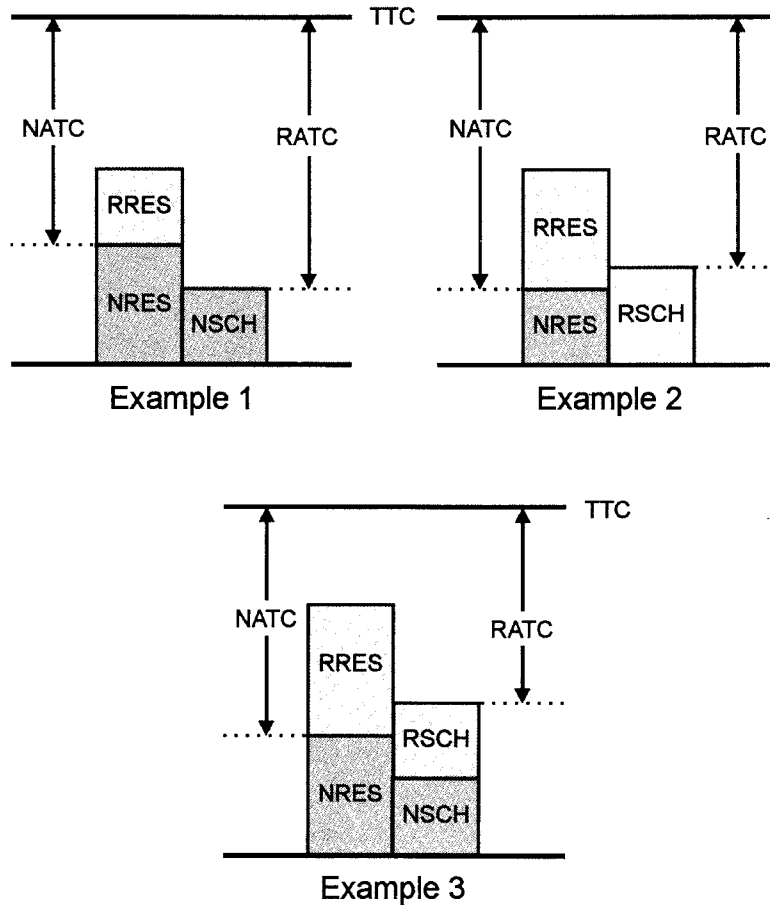

Transfer Capabilities		Transmission Services	
TTC	— Total Transfer Capability	NRES	— Non-recallable Reserved
ATC	— Available Transfer Capability	NSCH	— Non-recallable Scheduled
RATC	— Recallable ATC	RRES	— Recallable Reserved
NATC	— Non-recallable ATC	RSCH	— Recallable Scheduled

**Figure 4: ATC Relationships and Priorities**

# ATC DEFINITION AND DETERMINATION

---

- Non-recallable scheduled (NSCH) transfers are of the highest priority (all Examples). NSCH transfers cannot be curtailed by the transmission provider except in cases where system reliability is threatened or an emergency exists. All NSCH transfers reduce the amount of ATC.
- Recallable ATC (RATC) can include transfer capability that is currently held by non-recallable reserved (NRES) transfers. However, the new transfers scheduled from the RATC may have to be interrupted if the NRES transfer requester wants to make use of the transmission network (Example 1).
- Non-recallable ATC (NATC) cannot include transfer capability that is currently held by non-recallable reserved (NRES) transfers because the reserved transfer would have priority over any new non-recallable transfer (Examples 1 and 3).
- Non-recallable ATC (NATC) can include transfer capability that is currently used by recallable scheduled (RSCH) transfers because a non-recallable transfer has priority over recallable transfers (Example 3).
- Recallable ATC (RATC) cannot include transfer capability that is currently used by recallable scheduled (RSCH) transfers because the scheduled transfer would have priority over any new transfers (Examples 2 and 3).
- Both non-recallable ATC (NATC) and recallable ATC (RATC) can include recallable reserved (RRES) transfers (all Examples). However, any new recallable transfers may have to be interrupted if the RRES requester wants to make use of the transmission network (Examples 2 and 3).

The Examples in Figures 3 and 4 illustrate how ATC may be applied in the conduct of commercial business. These definitions have no impact on the physical determination of how much additional transfers the network can support.

Appendix C further demonstrates the interaction between recallable and non-recallable transmission service and the effects on ATC values.



## APPENDIX A. NETWORK RESPONSE METHOD FOR ATC DETERMINATION

The example in this Appendix describes an ATC calculation approach that may be termed a “network response” method. It demonstrates the ATC Principles described in this report and the physical impacts of electric power transfers on an interconnected transmission network. The method is intended to be illustrative of a procedure that is applicable in highly dense, meshed transmission networks where customer demand, generation sources, and the transmission systems are tightly interconnected. In such networks, transmission paths critical to a particular electric power transfer cannot generally be identified in advance. The critical path will be very much a function of the conditions that exist at the time the transfer is scheduled. The example does not introduce any concepts not covered in the front or main portion of this report.

### PHYSICAL SYSTEM IMPACTS OF TRANSFERS

Determination of ATC requires some translation from the area to area transactions to the resultant electric power flows on the transmission network. This translation is done by stressing the system with appropriate transfers under critical contingencies to determine the characteristic response of the network. These network response characteristics, which are based on the line outage, power transfer, and outage transfer distribution factors of NERC’s May 1995 NERC *Transmission Transfer Capability* reference document, can be determined by transfer capability studies either beforehand, or on a transaction-by-transaction basis.

When electric power is transferred between two areas such as Area A to Area F in Figure A1, the entire network responds to the transaction. The power flow on each transmission path will change in proportion to the response of the path to the transfer. Similarly, the power flow on each path will change depending on network topology, generation dispatches, customer demand levels, other transactions through the area, and other transactions that the path responds to which may be scheduled between other areas.

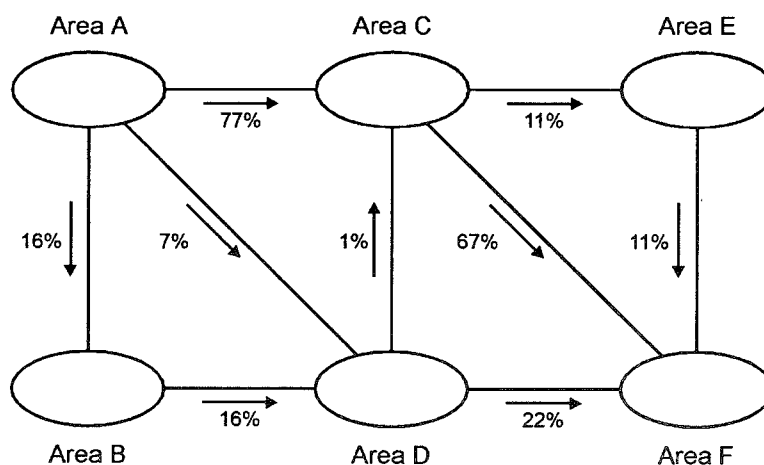
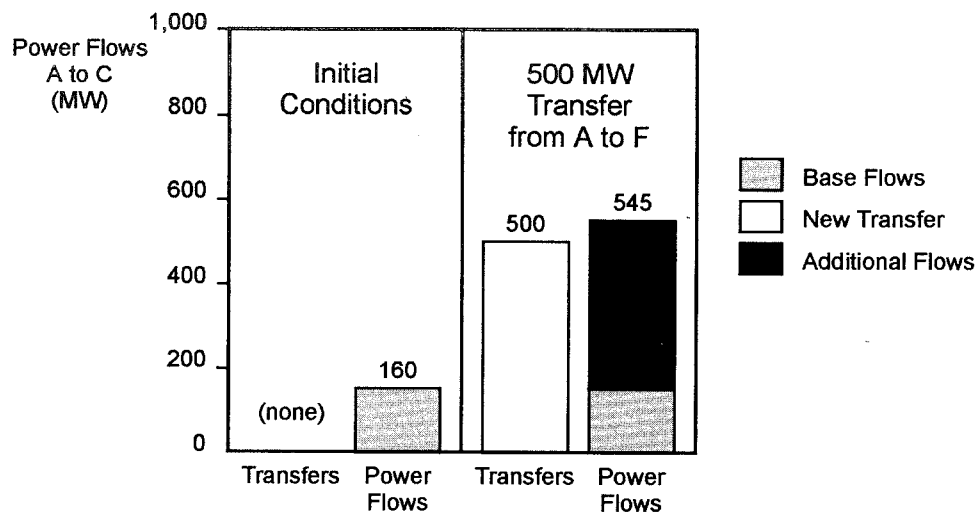

Figure A1: Network Response Characteristics for Area A to Area F Transfers

## APPENDIX A. NETWORK RESPONSE METHOD FOR ATC DETERMINATION

To illustrate this, computer simulation studies are performed to determine the transfer capability from Area A to Area F. During that process, it is determined that 77% of electric power transfers from Area A to Area F will flow on the transmission path between Area A and Area C (Figure A1).

Through application of those response characteristics, the impact on the path between Area A and Area C for a 500 MW transfer from Area A to Area F is graphically described in Figure A2. In this example, a pre-existing 160 MW power flow exists from Area A to Area C due to a generation dispatch and the location of customer demand centers on the modeled network. When a 500 MW transfer is scheduled from Area A to Area F, an additional 385 MW (77% of 500 MW) flows on the transmission path from Area A to Area C, resulting in a 545 MW power flow from Area A to Area C.

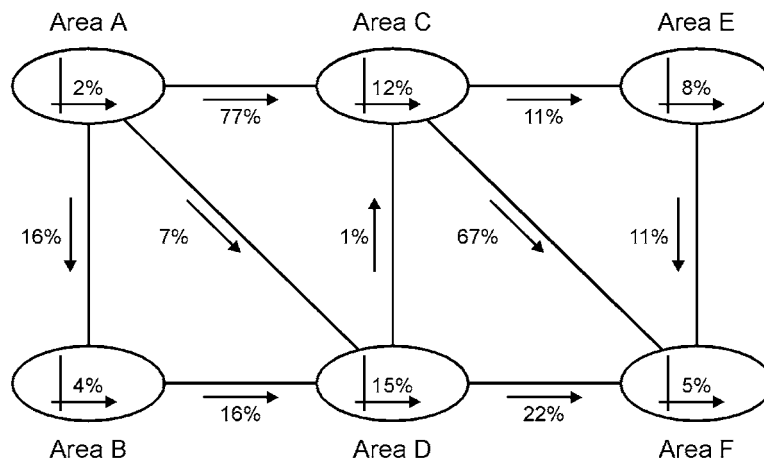

**Figure A2: Existing vs. Resultant Power Flows on Path A to C for a 500 MW Transfer from Area A to Area F**

To determine the ability of the network to transfer electric power from Area A to Area F, additional potential impacts within the individual areas must also be recognized. The network responses shown in Figure A1 must be expanded to consider possible transmission limits within each area.

The response characteristics of limiting facilities within the individual areas for an Area A to Area F transfer are shown in Figure A3. For simplicity, the flows within each area are not shown. Rather, the figures within each area represent the percentage of the transfer from Area A to Area F that flows on the most limiting facility within each area. Recognition of the limiting path responses within the individual areas for Area A to Area F transfers increases the complexity of determining the Area A to Area F ATC.

## APPENDIX A. NETWORK RESPONSE METHOD FOR ATC DETERMINATION



**Figure A3: Internal and Interconnection Responses to Area A to Area F Transfers**

### TRANSLATION OF SYSTEM IMPACTS TO ATC

The ATC of the network depends on the existing loading conditions on the limiting transmission facility, wherever it may be, taking into account contingency criteria (i.e., outage of the most critical line or generator or multiple lines and generators, as appropriate).

ATC is a function of how much unused or unloaded capacity is available on the most limiting transmission facility, allowing for single and, in some cases, multiple contingencies. The translation of the unused capacity of the transmission network to ATC determination for a particular direction is illustrated in Table 1, which refers to the transmission network shown in Figure A3 for an Area A to Area F transfer. The unused capacity of individual facilities in the transmission network, which is the difference between a facility's rating and its current power flow loading or its "available loading capacity," is divided by the response characteristic of the path facility to an Area A to Area F transfer. This procedure provides the individual critical path ATCs (in a system or between systems) from which the ATC from Area A to Area F is then determined by considering the most limiting path ATC. In this case, the limiting path is in Area D and the Area A to Area F ATC is 1,200 MW.

For a different electric power transfer, a new set of network responses and a new set of available capacity on limiting facilities would need to be determined to define the ATC for that transfer.

Electric power transfers have historically been scheduled between control areas on a contract path or area interchange basis. However, in the determination of ATCs, the actual flows on the network must be considered regardless of the scheduling methodology. In the preceding example, an electric power transfer may be scheduled from Area A to Area F, using a contract path from Area A to Area C to Area F. However, the reality of alternating current electrical systems is that the electric power would flow from Area A to Area F over the entire network, governed by the laws of physics. The electric power flowing on portions of the network other than the scheduled contract path is known as parallel path

## APPENDIX A. NETWORK RESPONSE METHOD FOR ATC DETERMINATION

System or Path	Network Response (%)	Available Loading Capacity (ALC) on Limiting Facility (MW)	System or Path ATC (MW)	Area A to Area F ATC (MW)
Area A	2	35	1,750	
Area B	4	92	2,300	
Area C	12	454	3,780	
Area D	15	180	1,200	1,200
Area E	8	200	2,500	
Area F	5	250	5,000	
A – C	77	1,000	1,300	
A – D	7	157	2,240	
A – B	16	440	2,750	
B – D	16	512	3,200	
C – E	11	198	1,800	
C – D	1	18	1,800	
C – F	67	1,072	1,600	
D – F	22	385	1,750	
E – F	11	214	1,945	

**Table 1: Available Transfer Capability Matrix for Transfers from Area A to Area F**

flows, and can affect many systems in an interconnected network. In this particular example, the transmission limit in Area D limits the Area A to Area F transfers to 1,200 MW.

### ATC TIME VARIATION AND NETWORK DEPENDENCY

Network conditions will vary over time, changing line loading conditions, and causing the ATC of the network to change. Also, the most limiting facility in determining the network's ATC can change from one time period to another, particularly in highly meshed networks. Therefore, the ATC of the network is time dependent.

# APPENDIX A. NETWORK RESPONSE METHOD FOR ATC DETERMINATION

This characteristic is illustrated conceptually in Figure A4. The first group of graphs on the left-hand side of the figure presents the available loading capacity at different points in time ( $T_1$ ,  $T_2$ ,  $T_3$ ) for several lines in an interconnected network. If an Area A to Area B transfer is to be scheduled at  $T_1$ , each of the lines (line 1 in Area A, line 3 in Area B, line 7 in Area B, and line 16 in Area D) will respond to the transfer in accordance with its network response factor. This factor is used to determine an ATC as limited by each individual facility. The results are shown on the middle set of diagrams of Figure A4. The ATC for the network as a whole represents the minimum of the ATCs as defined by each facility at each time frame. These minimum ATCs are schematically illustrated in the right side of Figure A4. As demonstrated, the ATC is different for each time period and is determined by a different facility in each period.

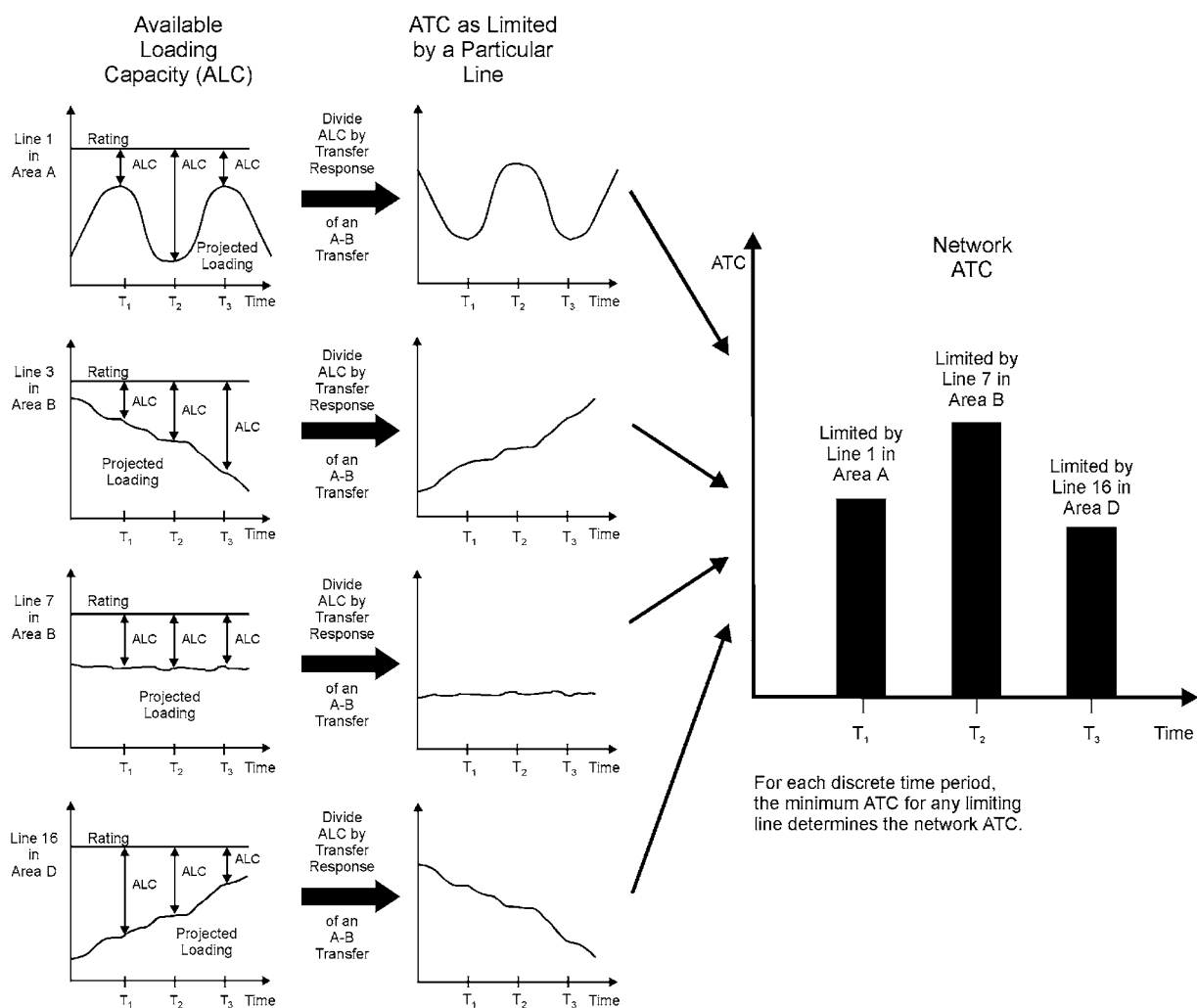

Figure A4: ATC Variance

## APPENDIX A. NETWORK RESPONSE METHOD FOR ATC DETERMINATION

The determination of ATC and the difference between simultaneous and non-simultaneous transfers are demonstrated in Tables 2 and 3. These ATC demonstrations are based on the sample six system network shown in Figure A3.

Area	Facility	Network Response (%)	ALC* on Limiting Facility (MW)	Area to Area ATC (MW)
Area A to Area F Transfer				
D	D1	15	180	1,200
Area B to Area E Transfer				
B	B1	5	25	500
Area E to Area A Transfer				
A	A2	7	103	1,470

\*Available Loading Capacity

**Table 2: Non-Simultaneous ATC Analyses**

Table 2 presents the non-simultaneous ATC analyses for three representative transfer conditions: Area A to Area F, Area B to Area E, and Area E to Area A. For each transfer direction, the area to area ATC is determined by the most critical system contingency and the resultant limiting system element, varying from 500 MW for an Area B to Area E transfer (limited by line B1 in Area B) to 1,470 MW for an Area E to Area A transfer (limited by line A2 in Area A).

Area	Facility	Network Response (%)	ALC* on Limiting Facility (MW)	Area to Area ATC (MW)
Area A to Area F ATC Analysis				
With a Pre-existing Area B to Area E 500 MW Transfer				
B	B1	3.5	0	0
Area A to Area F ATC Analysis				
With a Pre-existing Area B to Area E 500 MW Transfer and a Pre-existing Area E to Area A 1,470 MW Transfer				
B	B1	3.5	40	1,140

\*Available Loading Capacity

**Table 3: Simultaneous ATC Analyses**

## APPENDIX A. NETWORK RESPONSE METHOD FOR ATC DETERMINATION

---

The first section of Table 3 shows a determination of ATC for an Area A to Area F transfer, assuming that an Area B to Area E 500 MW transfer schedule is already in effect. Under this condition, the Area A to Area F ATC is now reduced from 1,200 MW (Table 2) to zero. This change is due to the increased loading on line B1 due to the previously scheduled 500 MW transfer from Area B to Area E, making it the limiting network facility. Note that the Area A to Area F transfer limiting facility was line D1 in Area D in the non-simultaneous analysis (Table 2).

The second portion of Table 3 is another determination of ATC for an Area A to Area F transfer. In this example, pre-existing transfers are in place from Area B to Area E of 500 MW and Area E to Area A of 1,470 MW. Under these conditions, the ATC for an Area A to Area F transfer is found to be 1,140 MW. This transfer is a slight reduction from the 1,200 MW ATC determination in the non-simultaneous case (Table 2), but is a significant increase from the zero ATC found in the previous case (first part of Table 3). This increased transfer is due to the offsetting effect of the flows caused by the pre-existing Area E to Area A transfer, which reduced the line loading on the critical facility B1, thus increasing the ATC for the Area A to Area F transfer direction.

These examples demonstrate that the determination of ATC in a tightly interconnected network is very much a function of system conditions that exist on the network at the time the transfer is to be scheduled. In addition, ATC is a function of the specifics of the electric power transfer being considered in terms of its direction, amount, and duration. To be able to properly appraise the performance of tightly interconnected networks to support contemplated transfers (i.e., what is the ATC), a regional or wide-area approach must be considered so that all network conditions are properly taken into account.

## **APPENDIX B. RATED SYSTEM PATH METHOD FOR ATC DETERMINATION**

---

### **OVERVIEW**

The rated system path (RSP) method for ATC determination is typically used for transmission systems that are characterized by sparse networks with customer demand and generation centers distant from one another. Generally in this approach, paths between areas of the network are identified and appropriate system constraints determined. ATC is computed for these identified paths and interconnections between transmission providers.

The RSP method involves three steps: 1) determining the path's Total Transfer Capability (TTC), 2) allocating the TTC among owners in a multi-owned path to determine the owners' rights, and 3) calculating ATC for each right-holder by subtracting each of their uses from each of their individual TTC rights. Wide-area coordination is achieved by developing the TTC in a manner that follows a regional review process. This process assures individual, power pool, subregional, and Regional coordination and the necessary consideration of the interconnection network's constraints and conditions.

The RSP method includes a procedure for allocating TTC, and in turn ATC, among the owners of the transmission path(s). It should be noted that the RSP method of allocation is not the only procedure that may be followed in allocating transmission services.

### **UNSCHEDULED FLOW OR PARALLEL PATH FLOW**

The RSP approach accounts for the effects of unscheduled flow (parallel path flow) on interconnected systems through the modeling of realistic customer demand and generation patterns in advance of real-time operations, and uses a maximum power flow test to ensure that the transfer path is capable of carrying power flows up to its rated transfer capability or TTC.

The rating process begins by modeling the interconnected network with the actual flow that will occur on the path and its parallel paths under realistically stressed conditions. The lines comprising the path may be rated and operated as a single path. The network is tested under a wide range of generation, customer demand, and facility outage conditions to determine a reliability-based TTC. When determined this way, the TTC rating usually remains fairly constant except for system configuration changes such as a line outage situation. To implement the RSP ATC method, consistent path rating methods and procedures must be agreed upon and followed within the Interconnection.

Non-simultaneous ratings are normally used as the basis for calculating ATC. If, however, two rated paths have a simultaneous effect on each other, the rating process identifies the simultaneous capabilities or establishes nomograms that govern the simultaneous operation of the paths. Applicable operating procedures are negotiated to ensure reliable network operation. Where simultaneous operation is necessary, operator control is used to ensure safe and reliable operation of the transmission network.



## **APPENDIX B. RATED SYSTEM PATH METHOD FOR ATC DETERMINATION**

---

### **CAPACITY ALLOCATION**

The reliability-based TTC of a transfer path (its reliability rating) is allocated among the right-holders based upon their negotiated agreement. This determination of the property rights through the allocation process is critical to the RSP implementation of ATC. The rights in the path are negotiated for each of the individual transmission providers. Except for deratings based upon system operating (e.g., emergency) conditions, these allocations become rights that the right-holder may use or resell to others as non-recallable or recallable service.

Although the actual flows from each right-holder's schedule will flow on all parallel lines, the advance allocation of rights on a path makes it possible for right-holders to determine ATC and sell service within their rights independent of others. If the rating is determined using appropriate path rating procedures, including a maximum power flow test, the potential for adverse unscheduled power flow effects is minimized.

In real time, neither the total of the schedules, nor the actual power flow on a path may exceed the path TTC. Although the potential for adverse unscheduled power flow is minimized as a result of the modeling and rating process, some acceptable or mitigatable unscheduled flows will usually occur during real-time operation. Regions that use RSP to calculate ATC should adopt an unscheduled flow mitigation plan which addresses such flows, if they adversely affect system operation. The adverse flows can be managed through schedule changes, installing controllable devices such as phase shifters, or including this uncertainty as part of the reliability margin.

### **ATC CALCULATION APPROACH**

1. Each path for which ATC must be calculated is identified, and then a reliability-based TTC is determined as described above. This TTC is then allocated among the owners by negotiated agreement.
2. Deratings for outages, nomograms, maintenance, or unscheduled flow are allocated, if necessary, to the right-holders based on prearranged agreements or tariffs.
3. Right-holders take their respective allocated shares of the TTC for a path and subtract the existing commitments to determine the appropriate ATC.
4. Right-holders update and repost their ATC calculations as new commitments impact their ATC. A transfer from one area to another involving several transmission owners requires locating and reserving capacity across multiple paths and potentially multiple right-holders.

### **EXAMPLE OF ATC DETERMINATION**

The following example illustrates the application of the RSP method for determining ATC in a sparse network. The example transmission network is shown in Figure B1. All paths that connect the various areas have transfer capabilities that were individually developed in coordination with all areas giving consideration to unscheduled flow and interconnection interactions and effects. The TTCs portrayed in

## APPENDIX B. RATED SYSTEM PATH METHOD FOR ATC DETERMINATION

Figure B2 are shown for each path and are directional, but are not necessarily the same for each direction.

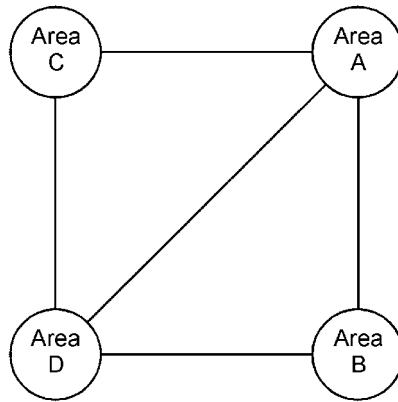

**Figure B1: Sparse Network Model**

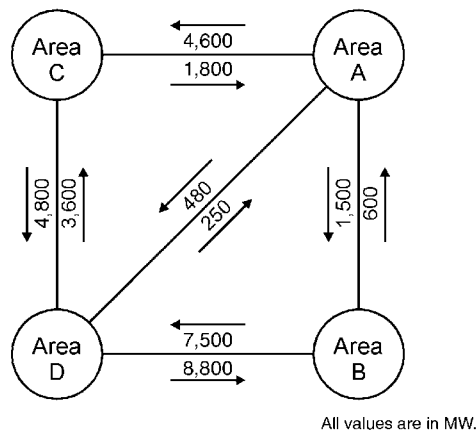

**Figure B2: Total Transfer Capabilities**

Each path may consist of several transmission lines that can also have different owners. In this example, the path between Areas B and D is comprised of five lines as shown in Figure B3. The TTC from Area B to Area D is 7,500 MW and, in the reverse direction, 8,800 MW. Line 1 is owned by a single entity and has an allocated portion of the TTC equal to 1,300 MW in either direction.

## APPENDIX B. RATED SYSTEM PATH METHOD FOR ATC DETERMINATION

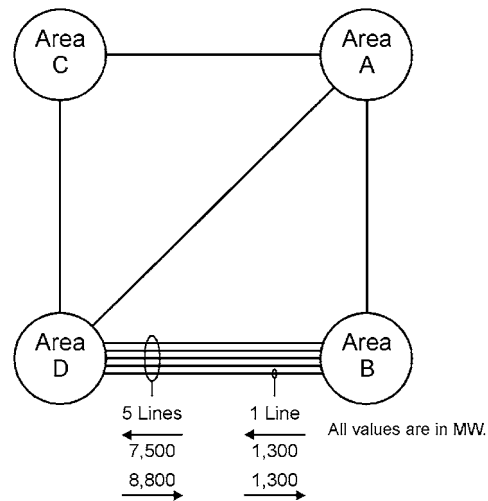

**Figure B3: TTCs of Path B to D and Allocation of TTCs to Line 1**

This example reflects a snapshot in time during the planning horizon. Initial transmission service reservations, all assumed to be non-recallable, are shown for each path in Figure B4. The corresponding ATC for each path has been calculated by subtracting the non-recallable service from the TTC. Because all the transmission service reservations are assumed on each path to be in one direction, the path ATC is only calculated for that direction.

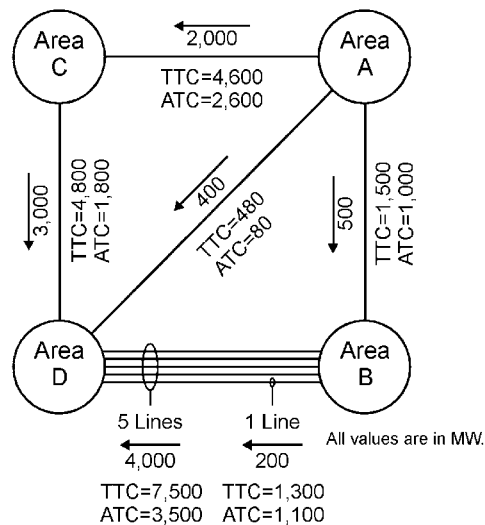

**Figure B4: Initial Transmission Service Reservations**

## APPENDIX B. RATED SYSTEM PATH METHOD FOR ATC DETERMINATION

For example, referring to Figure B4, the ATC from Area B to Area D is calculated as 7,500 MW less 4,000 MW or 3,500 MW. For line 1 of the B to D path, the ATC is 1,300 MW less 200 MW or 1,100 MW. In the next case, as shown in Figure B5, 1,000 MW of non-recallable transmission service is acquired from Area A to Area B to Area D. No other changes occur. The total transmission service reserved from Area A to Area B is 1,500 MW, and the resulting ATC goes to zero. The ATC from Area B to Area D reduces to 2,500 MW (7,500 MW TTC less 5,000 MW reserved transmission service). It is assumed the 1,000 MW of the new reserved transmission service was obtained from the owner of line 1, resulting in the total reserved transmission service on this line being 1,200 MW. The new ATC for line 1 is 100 MW (1,300 MW TTC less 1,200 MW reserved transmission service).

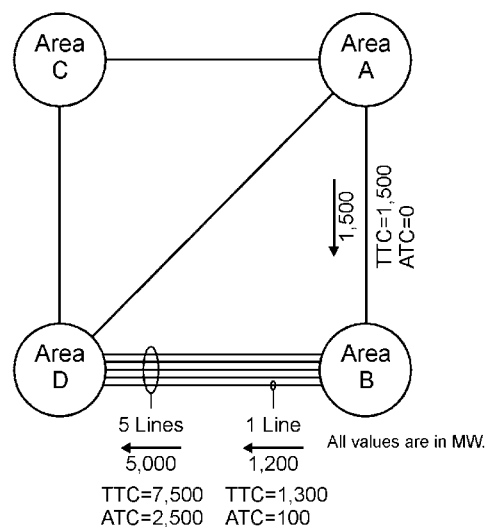

**Figure B5: New Transmission Service Reservation on Path A to B to D**

The non-recallable transmission service reserved for a path in each direction may not exceed the path's transfer capability in either direction under any circumstances. These limits are consistent with NERC Operating Policies.

Unscheduled flow may at times preclude scheduling to a path's full transfer capability or TTC. If an internal limit is encountered in any system as a result of the transaction from Area A to Area D, for example in Area D, Area D's system operator must respond to relieve the limitation such as by redispatching generation or using phase shifter control. An unscheduled flow mitigation plan might also be implemented to relieve excessive unscheduled flow problems. Additional relief may be achieved by curtailing schedules that are contributing to the unscheduled flow on the path or by increasing schedules that would create unscheduled flow in the opposite direction. In this example, if path A to D were limiting, unscheduled flow mitigation procedures could be implemented to initiate coordinated operation of controllable devices such as phase-shifting transformers to relieve the limitation.

## **APPENDIX B. RATED SYSTEM PATH METHOD FOR ATC DETERMINATION**

---

There will probably be times in the operating horizon when the use of the transmission network results in actual flows on a transmission path being less than the transmission scheduled on the path. During these periods, if the transmission path is fully scheduled, additional electric power may be scheduled to Area D from Area A by reserving transmission service over a different transmission path. In this case, transmission service could be obtained from either the owners of the direct path between Area A and Area D or the owners of the transmission system from Area A to Area C to Area D.

For the RSP method, the transmission rights to be reserved and scheduled by all transmission users are consistent with the rating of the transmission paths. If determined through a coordinated process using models that capture the major effects of the interconnected network, these ratings will create limits that result in the reliable operation of the regional electric system. The owners of the transmission paths, through a negotiated allocation process, will know their transmission service rights and the resulting use of these rights will be consistent with the physical capability and limitations of the transmission network. This RSP method assures efficient use and reliable operation of the interconnected transmission network.

## APPENDIX C. TRANSMISSION SERVICE RESERVATIONS AND SCHEDULING

---

### OVERVIEW

The following scenarios demonstrate how the 1,200 MW ATC quantity from Area A to Area F in the example in Appendix A may be commercially employed. The interplay between recallable and non-recallable transmission service and the resulting effects upon calculated ATCs are demonstrated using the equations presented in the “ATC Definition and Determination” section of this report. They clearly demonstrate that, although both recallable and non-recallable ATC are offered simultaneously, the combined total of recallable and non-recallable service does not exceed the TTC at any time.

For the purpose of this illustration, assume that conditions on the interconnected network are as described in Tables 1 and 2 of Appendix A. Under this scenario, the network ATC from Area A to Area F for this time period in the operating horizon is 1,200 MW. Also, for simplicity, assume that previous transmission commitments are zero. Thus, TTC in the following cases is 1,200 MW. Lastly, assume that TRM is zero. The resulting relevant simplified ATC equations for the operating horizon are:

$$\text{NATC} = \text{TTC} - \text{NRES}$$

$$\text{RATC} = \text{TTC} - \text{RSCH} - \text{NSCH}$$

The equations that describe the TTC constraints during this time frame are:

$$\text{NRES} \leq \text{TTC}$$

$$\text{RSCH} + \text{NSCH} \leq \text{TTC}$$

### ATC DEMONSTRATION — SCENARIO 1

Consider the initial case identified in Figure C1 as Case 1. Reservations for 200 MW of recallable and 400 MW of non-recallable transmission service have been reserved against the 1,200 MW TTC.

Case 1 includes schedules for only 300 MW of non-recallable transmission service. Thus:

$$\begin{aligned}\text{NATC} &= \text{TTC} - \text{NRES} \\ &= 1,200 - 400 \\ &= 800 \text{ MW}\end{aligned}$$

$$\begin{aligned}\text{RATC} &= \text{TTC} - \text{RSCH} - \text{NSCH} \\ &= 1,200 - 0 - 300 \\ &= 900 \text{ MW}\end{aligned}$$

# APPENDIX C. TRANSMISSION SERVICE RESERVATIONS AND SCHEDULING

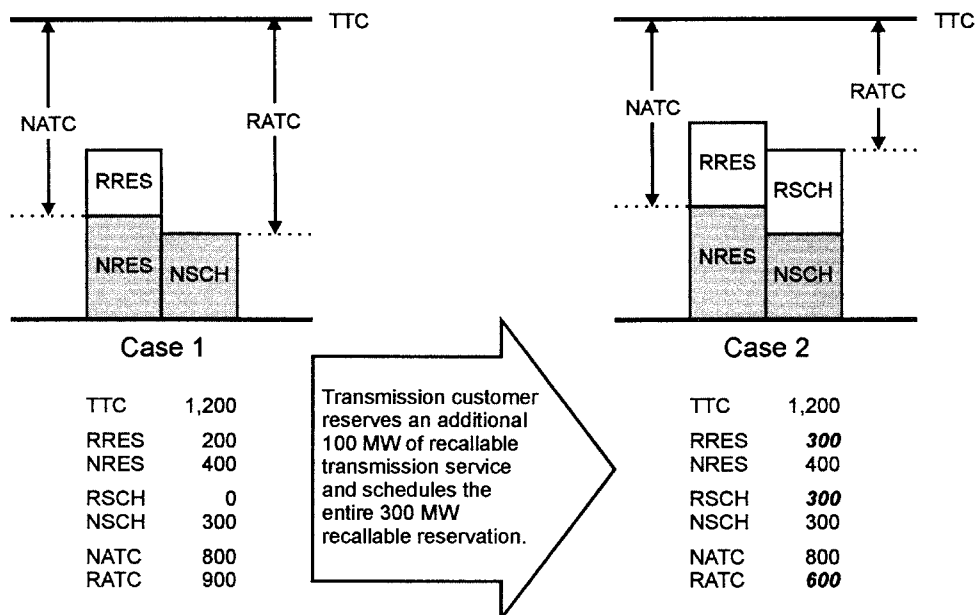

Transfer Capabilities		Transmission Services	
TTC	— Total Transfer Capability	NRES	— Non-recallable Reserved
ATC	— Available Transfer Capability	NSCH	— Non-recallable Scheduled
RATC	— Recallable ATC	RRES	— Recallable Reserved
NATC	— Non-recallable ATC	RSCH	— Recallable Scheduled

**Figure C1: ATC Demonstration — Scenario 1**

In Scenario 1, the transmission customer reserves an additional 100 MW of recallable transmission service and schedules the entire 300 MW recallable reservation. The results are shown in Figure C1 as Case 2. (Note that changed values are shown in bold italic type.) Non-recallable ATC is unchanged, but recallable ATC is changed as follows:

$$\begin{aligned}
 \text{RATC} &= \text{TTC} - \text{RSCH} - \text{NSCH} \\
 &= 1,200 - 300 - 300 \\
 &= 600 \text{ MW}
 \end{aligned}$$

# APPENDIX C. TRANSMISSION SERVICE RESERVATIONS AND SCHEDULING

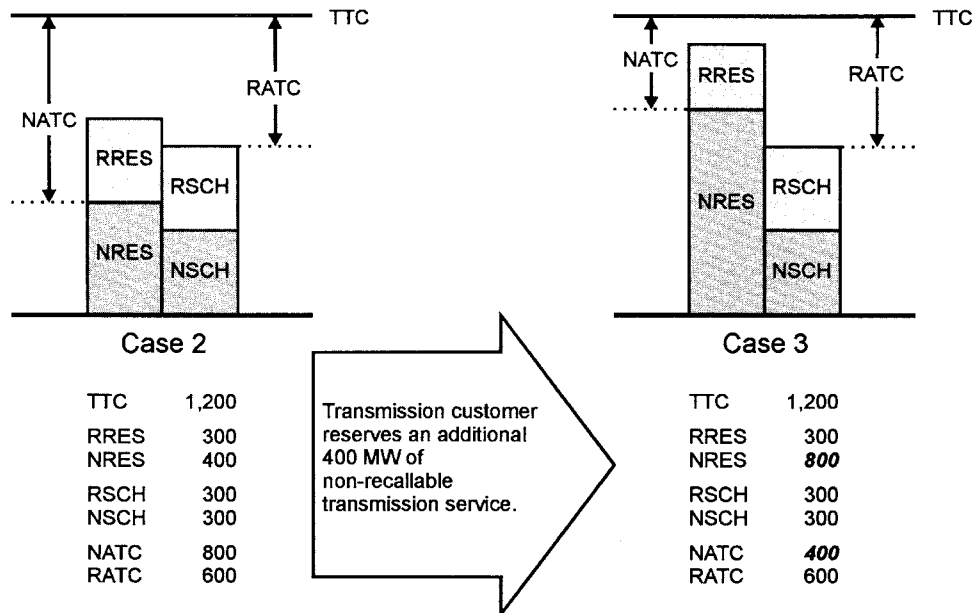

Transfer Capabilities		Transmission Services	
TTC	— Total Transfer Capability	NRES	— Non-recallable Reserved
ATC	— Available Transfer Capability	NSCH	— Non-recallable Scheduled
RATC	— Recallable ATC	RRES	— Recallable Reserved
NATC	— Non-recallable ATC	RSCH	— Recallable Scheduled

**Figure C2: ATC Demonstration — Scenario 2**

## ATC DEMONSTRATION — SCENARIO 2

In Scenario 2 of Figure C2, the transmission customer reserves an additional 400 MW of non-recallable transmission service. The results are shown in Figure C2 as Case 3. Recallable ATC is unchanged in this scenario, but non-recallable ATC is changed as follows:

$$\begin{aligned}
 \text{NATC} &= \text{TTC} - \text{NRES} \\
 &= 1,200 - 800 \\
 &= 400 \text{ MW}
 \end{aligned}$$



# APPENDIX C. TRANSMISSION SERVICE RESERVATIONS AND SCHEDULING

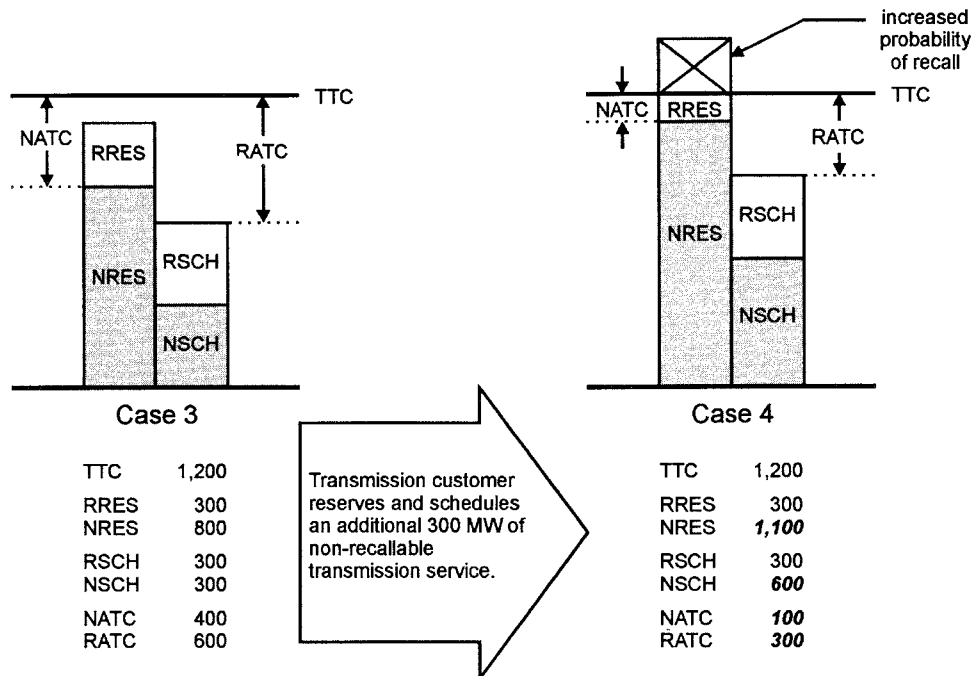

Transfer Capabilities	Transmission Services
TTC — Total Transfer Capability	NRES — Non-recallable Reserved
ATC — Available Transfer Capability	NSCH — Non-recallable Scheduled
RATC — Recallable ATC	RRES — Recallable Reserved
NATC — Non-recallable ATC	RSCH — Recallable Scheduled

**Figure C3: ATC Demonstration — Scenario 3**

## ATC DEMONSTRATION — SCENARIO 3

In Scenario 3 of Figure C3, the transmission customer reserves and schedules an additional 300 MW of non-recallable transmission service. The results are shown in Figure C3 as Case 4. In this scenario, both recallable and non-recallable ATCs are changed as follows:

$$\begin{aligned}
 \text{NATC} &= \text{TTC} - \text{NRES} \\
 &= 1,200 - 1,100 \\
 &= 100 \text{ MW}
 \end{aligned}$$

$$\begin{aligned}
 \text{RATC} &= \text{TTC} - \text{RSCH} - \text{NSCH} \\
 &= 1,200 - 300 - 600 \\
 &= 300 \text{ MW}
 \end{aligned}$$

Transmission customers holding the 200 MW of recallable transmission service reservations “above the TTC line” should be advised that they have a high probability of having their transmission service recalled.

# APPENDIX C. TRANSMISSION SERVICE RESERVATIONS AND SCHEDULING

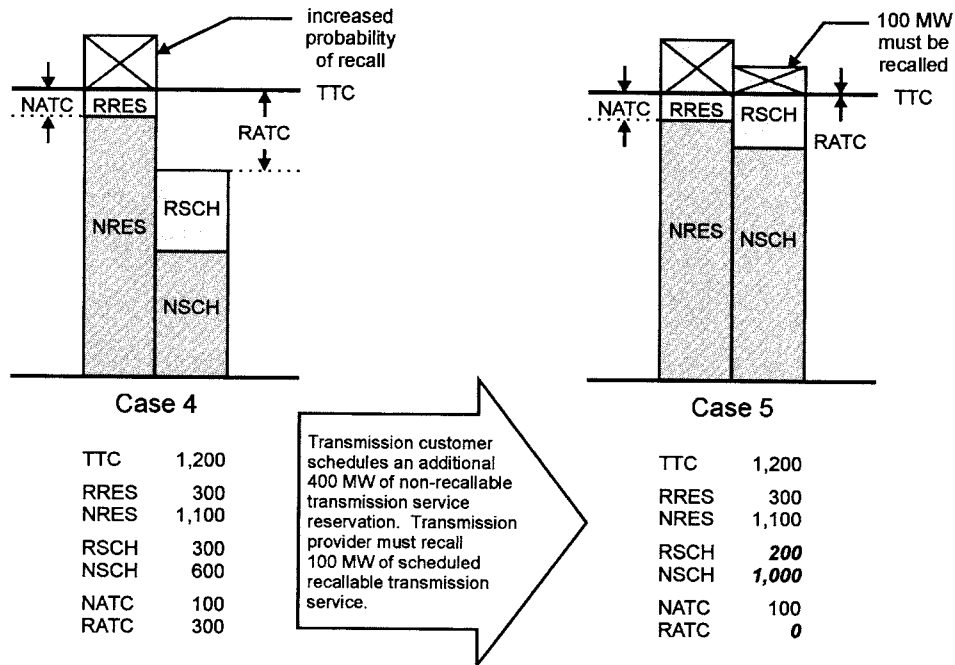

Transfer Capabilities		Transmission Services	
TTC	— Total Transfer Capability	NRES	— Non-recallable Reserved
ATC	— Available Transfer Capability	NSCH	— Non-recallable Scheduled
RATC	— Recallable ATC	RRES	— Recallable Reserved
NATC	— Non-recallable ATC	RSCH	— Recallable Scheduled

Figure C4: ATC Demonstration — Scenario 4

## ATC DEMONSTRATION — SCENARIO 4

In Scenario 4 of Figure C4, the transmission customer schedules an additional 400 MW of non-recallable transmission service. The results are shown in Figure C4 as Case 5. Non-recallable ATC remains unchanged at 100 MW. Unless 100 MW of recallable transmission service schedules are recalled, the total schedules violate the TTC constraint. The transmission provider must recall 100 MW of scheduled recallable transmission service. The recallable ATC calculation is then:

$$\begin{aligned}
 \text{RATC} &= \text{TTC} - \text{RSCH} - \text{NSCH} \\
 &= 1,200 - 200 - 1,000 \\
 &= 0 \text{ MW}
 \end{aligned}$$

As this demonstration has shown, recallable transmission services may be reduced as non-recallable transmission services are reserved and scheduled, approaching the TTC limit.

# TRANSMISSION TRANSFER CAPABILITY TASK FORCE

---

**Raymond M. Maliszewski (Chairman)**  
Senior Vice President–System Planning  
American Electric Power Service Corporation  
Columbus, Ohio

**Garey C. Rozier (Vice Chairman)**  
Director of Bulk Power Supply  
Southern Company Services, Inc.  
Atlanta, Georgia

**Robert W. Cummings (ECAR)**  
Manager, Transmission Services  
East Central Area Reliability Coordination  
Agreement  
Canton, Ohio

**Lee E. Westbrook (ERCOT)**  
Transmission Grid Planning Manager  
TU Electric  
Dallas, Texas

**Bruce M. Balmat (MAAC)**  
Manager, System Services & Performance  
PJM Interconnection Association  
Norristown, Pennsylvania

**T.J. (Jim) Barker (MAIN)**  
Manager–Electric System Engineering Department  
Central Illinois Public Service Company  
Springfield, Illinois

**Terry L. Bundy (MAPP, Municipal, and  
Transmission Dependent Utility)**  
Manager, P/wer Supply Division  
Lincoln Electric System  
Lincoln, Nebraska

**Edward A. Schwerdt (NPCC and Canada)**  
Director of Engineering  
Northeast Power Coordinating Council  
New York, New York

**W.T. (Terry) Boston (SERC and Federal)**  
Division Manager, Electric System Reliability  
Tennessee Valley Authority  
Chattanooga, Tennessee

**Nicholas A. Brown (SPP)**  
Director, Engineering & Operations  
Southwest Power Pool  
Little Rock, Arkansas

**Harlow R. Peterson (WSCC)**  
Consultant Planning Analyst  
Salt River Project  
Phoenix, Arizona

**John L. Griffin (WSCC)**  
Senior Engineer/Policy Analyst  
Grid Customer Services  
Pacific Gas and Electric Company  
San Francisco, California

**William C. Phillips (Operating Committee  
Liaison)**  
Director, Power System Operations  
Entergy Services, Inc.  
Pine Bluff, Arkansas

**Robert Wayne Mitchell (Operating Committee  
Liaison Alternate)**  
System Operations Analyst III  
Entergy Services, Inc.  
Pine Bluff, Arkansas

**C.M. (Marty) Mennes (NERC Electronic  
Information Network Task Force)**  
Director P/wer Supply  
Florida Power & Light Company  
Miami, Florida

**Paul F. Barber (P/wer Marketer)**  
Vice President, Transmission and Engineering  
Citizens Lehman Power L.P.  
Boston, Massachusetts

**Trudy Utter (Independent Power Producer)**  
Vice President & General Manager  
Tenaska P/wer Services Company  
Arlington, Texas

**Virginia C. Sulzberger (NERC Staff)**  
Director–Engineering  
North American Electric Reliability Council  
Princeton, New Jersey

# North American Electric Reliability Council

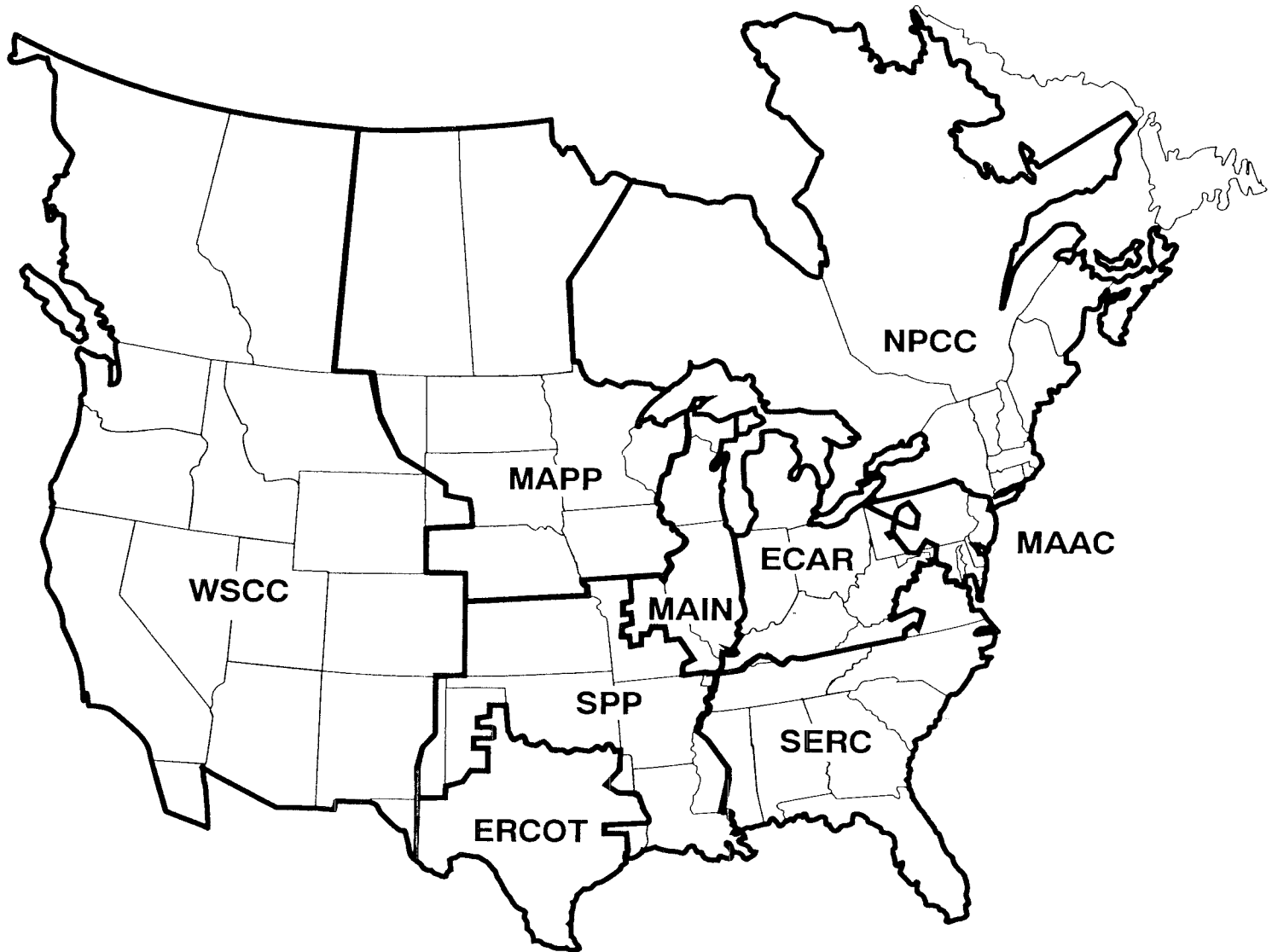

**ECAR**  
East Central Area Reliability Coordination Agreement

**ERCOT**  
Electric Reliability Council of Texas

**MAAC**  
Mid-Atlantic Area Council

**MAIN**  
Mid-America Interconnected Network

**MAPP**  
Mid-Continent Area Power Pool

**NPCC**  
Northeast Power Coordinating Council

**SERC**  
Southeastern Electric Reliability Council

**SPP**  
Southwest Power Pool

**WSCC**  
Western Systems Coordinating Council

*AFFILIATE*

**ASCC**  
Alaska Systems Coordinating Council